

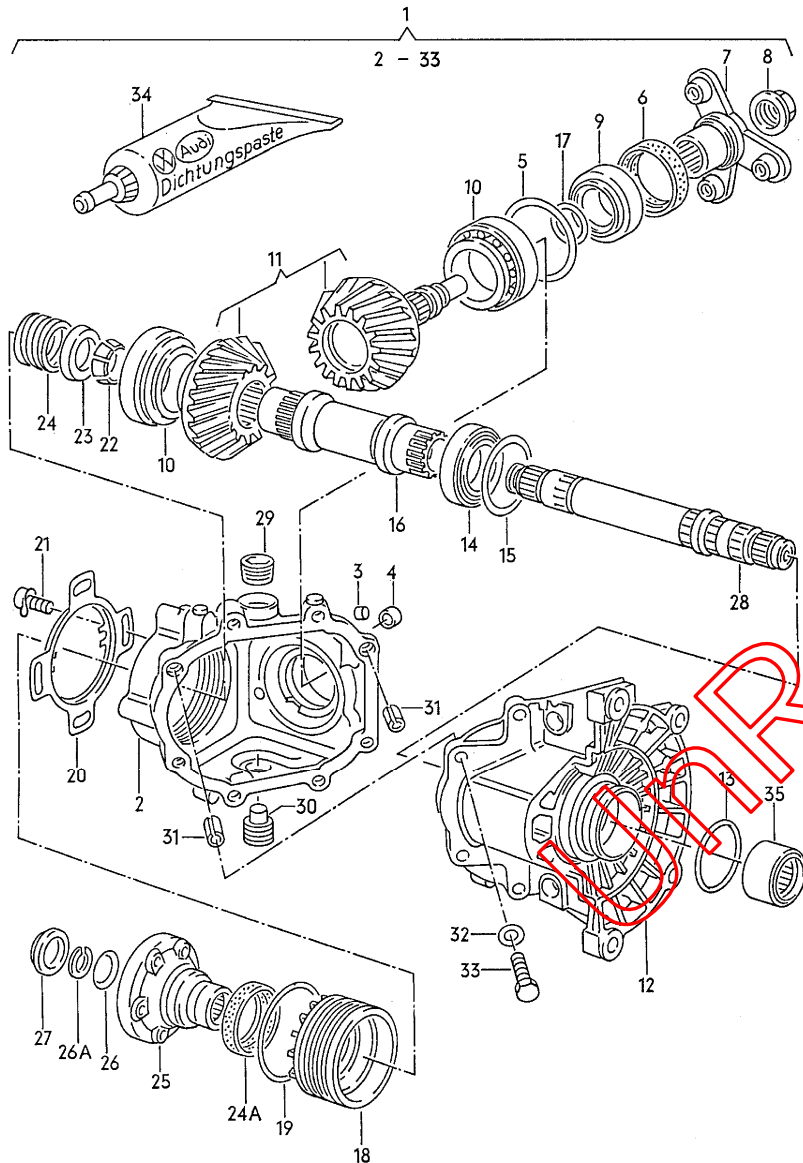

Model	Year	MG	SG	Illustration	Restrictions	UPD	14:39	06.11.2017		ETKA
GOSY	1989	4	09	100-00		622				



Pos	Part Number	Description	Remark	Qty	Model
		final drive	front		4Z, ARM, ATZ, AXR
(1)	c 009 409 053	final drive, complete G >> 31 12 8*	20/21	1	4Z
(1)	c 009 409 053 C	final drive, complete G 09 01 9>> 22 08 9*	20/21	1	ARM
(1)	009 409 053 B	final drive, complete B 24 08 9>>*	20/21	1	ATZ, AXR
2	009 409 107	final drive housing		1	4Z
(2)	009 409 107 A	final drive housing		1	ARM, ATZ, AXR
3	001 301 113	plug	7,1X9,3	2	
4	113 101 118 F	plug	13,2X7,5	1	
5	009 409 247	adjusting washer	0,15	X	
(5)	009 409 247 A	adjusting washer	0,3	X	
(5)	009 409 247 B	adjusting washer	0,35	X	
(5)	009 409 247 C	adjusting washer	0,4	X	
(5)	009 409 247 D	adjusting washer	0,5	X	
(5)	009 409 247 E	adjusting washer	0,6	X	
6	b 020 301 189 N	oil seal G >> 05 01 7	65X10 ED=6,4	1	4Z
(6)	b 020 301 189 T	oil seal G 06 01 7>>	50X65X10	1	4Z
(6)	b 084 409 189 B	oil seal	48X62X7	1	ARM, ATZ, AXR
7	009 409 273	flange		1	4Z
(7)	02C 409 271 A	flange		1	ARM, ATZ, AXR
8	N 904 133 01	hexagonal nut	M20X1,5	1	
9	411 501 283 E	taper roller bearing		1	
10	091 517 185 B	taper roller bearing	50X80X20	2	
11	009 409 143 A	pinion gear set	20/21	1	
12	009 409 305	end shield		1	

Model	Year	MG	SG	Illustration	Restrictions	UPD	14:39	06.11.2017		ETKA
GOSY	1989	4	09	100-00		622				

Pos	Part Number	Description	Remark	Qty	Model	Pos	Part Number	Description	Remark	Qty	Model
13	N 902 854 01	seal	54,5X3N	1		(17)	02C 409 280 E	adjusting washer	0,9	X	ARM,ATZ,AXR
14	113 517 185 D	taper roller bearing	41X68X17,6	1		(17)	02C 409 280 F	adjusting washer	0,95	X	ARM,ATZ,AXR
15	113 517 201 A	adjusting washer	0,15	X		(17)	02C 409 280 G	adjusting washer	1	X	ARM,ATZ,AXR
(15)	113 517 202 A	adjusting washer	0,2	X		(17)	02C 409 280 H	adjusting washer	1,05	X	ARM,ATZ,AXR
(15)	113 517 203 A	adjusting washer	0,3	X		(17)	02C 409 280 J	adjusting washer	1,1	X	ARM,ATZ,AXR
(15)	113 517 204 A	adjusting washer	0,4	X		(17)	02C 409 280 K	adjusting washer	1,15	X	ARM,ATZ,AXR
(15)	113 517 205 A	adjusting washer	0,5	X		(17)	02C 409 280 L	adjusting washer	1,2	X	ARM,ATZ,AXR
(15)	113 517 206 A	adjusting washer	0,6	X		(17)	02C 409 280 M	adjusting washer	1,25	X	ARM,ATZ,AXR
(15)	02A 409 210 A	adjusting washer	0,7	X		(17)	02C 409 280 N	adjusting washer	1,3	X	ARM,ATZ,AXR
(15)	02A 409 210 C	adjusting washer	0,8	X		(17)	02C 409 280 P	adjusting washer	1,35	X	ARM,ATZ,AXR
(15)	02A 409 210 E	adjusting washer	0,9	X		(17)	02C 409 280 Q	adjusting washer	1,4	X	ARM,ATZ,AXR
(15)	02A 409 210 G	adjusting washer	1	X		18	009 409 443	bearing ring		1	
(15)	02A 409 210 L	adjusting washer	1,2	X		19	N 901 702 01	round seal	85X3	1	
16	009 409 403	propshaft		1		20	009 409 447	lock plate		1	
17	009 409 280	adjusting washer	0,15	X	4Z	21	c N 090 173 3	fillister head bolt (combi.)	M7X1,25X13Z3	1	
(17)	c 009 409 280 A	adjusting washer	0,20	X	4Z	22	020 409 374	tapered ring		1	
(17)	c 009 409 280 B	adjusting washer	0,25	X	4Z	23	020 409 378	thrust washer		1	
(17)	c 009 409 280 C	adjusting washer	0,30	X	4Z	(24)	020 409 379 B	pressure spring			
(17)	009 409 280 D	adjusting washer	0,40	X	4Z	24A b	020 301 189 T	oil seal	50X65X10	1	
(17)	c 009 409 280 E	adjusting washer	0,50	X	4Z	25	020 409 285 N	joint flange	90	1	4Z,ARM
(17)	c 009 409 280 F	adjusting washer	0,60	X	4Z			also use:	020 301 189 T	1	
(17)	02C 409 280	adjusting washer	0,65	X	ARM,ATZ,AXR	(25)	020 409 285 Q	joint flange	100	1	ATZ,AXR
(17)	02C 409 280 A	adjusting washer	0,7	X	ARM,ATZ,AXR,4Z	26	020 409 295	concave spring washer		1	
(17)	02C 409 280 B	adjusting washer	0,75	X	ARM,ATZ,AXR	26A *	020 409 297	snap ring		1	
(17)	02C 409 280 C	adjusting washer	0,8	X	ARM,ATZ,AXR,4Z	27 *	020 409 289 B	locking cover		1	
(17)	02C 409 280 D	adjusting washer	0,85	X	ARM,ATZ,AXR	28	009 409 292	output shaft		1	
						29	012 301 127 F	sealing plug	M24X1,5	1	

Model	Year	MG	SG	Illustration	Restrictions	UPD	14:39	06.11.2017		ETKA
GOSY	1989	4	09	100-00		622				

Pos	Part Number	Description	Remark	Qty	Model	Pos	Part Number	Description	Remark	Qty	Model
30	113 301 141 B	oil drain plug, magnetic	M24X1,5	1							
31	02M 301 153	dowel sleeve G >> 11 01 7	12X9,5	2							
(31)	016 301 299	dowel sleeve G 12 01 7>>	12X11,5	2							
32	+ N 011 558 11	washer	8,4X15X1,6	8							
33	N 101 953 01	hexagon head bolt c/w shoulder	M8X35	8							
34	AMV 188 200 03	sealing paste	100G	X							
35	009 409 339	muff		1							

UnRegistered